

Durabilt

ASSEMBLING USE AND MAINTENANCE

RP/4-5

RAKE CADDY ADJUSTMENT INSTRUCTIONS

1. Locate an area that is approximately 20 feet square, that is level and flat. This is necessary for adjusting the rake wheels to ground pressure, which is explained in step # 6.
2. Locate each axle assembly from the center of the tool bar by using one of the following measurements:
 - 0" from center = 3 ft. wind row*
 - 6" from center = 4 ft. wind row*
 - 12" from center = 5 ft. wind row*

*Measurements when the rake tower plates are located in the center hole to center of steel angel on the rake caddy.
3. Place a wood block (2" x 4") under each tire to raise the caddy approximately 1-1/2" above the ground. Adjust jack to level the tongue.
4. Adjust each cylinder's length until each vertical tube is at a 90 degree angle to the ground. (A level can be used for this adjustment)
5. Slip the rake tower over the vertical tube on each axle assembly. Align one of the center holes in the tower plate with one of the center holes in the rake caddy tower assembly. Attach the rake tower to the rake with a 9/16" x 2" Hex Head bolt, washer, and locknut.

This position will provide further adjustment of the raking angle as required depending upon the condition of the hay that is to be raked.

NOTE:

When changing rake angles, the wind row width will be affected and axle assemblies to tool bar adjustments will have to be made.

6. Install the rakes per instruction as provided by the rake manufacturer. Each rake wheel must just clear the ground. Make any adjustments to the rake wheel by raising or lowering the springs on the rake tower. This will provide proper ground pressure on the rake wheels when the 2"x4" wood blocks are removed from under the tires.
7. Remove the wood blocks from under each tire and adjust the hitch on the rake caddy to maintain a level profile when connected to the tow vehicle.

NOTE:

Rakes of different manufacturers will be bolted together in different manners. Some rake towers will have only one bolt in center of the assembly, while others will have one bolt at the top and one bolt at the bottom of the tower, etc.

INTRODUCTION

This manual includes full instructions for a correct use and maintenance of the machinery, and the recommended spare parts list.

In order to prevent any possible damage of the machine and/or the operator(s) you are kindly requested to go through this manual for a proper knowledge of the assembly of the implements, their use on the field, and their maintenance. If any doubt, please contact your local dealer or distributor.

Should the machine be re-sold, you are kindly requested to supply this manual along with the machine to the new purchaser.

CAUTION FOR USE

It could be dangerous for people who are not familiar with this type of machine to use the rake, particularly when kids are there during the assembly or operation on field. We therefore recommend the use of the rake only to those people who are very familiar with the machine and the safety precautions.

ASSEMBLY SOLUTIONS

rakes are easily convertible into different sizes, as almost all parts are standard and interchangeable on all sizes (wheel arms, wheels - etc.). With a special frame it is possible to attach together two RP/4-RP/5-RP/6 rakes - R.H. and L.H. - and convert them into a V-rake.

Here are the advantages

- 1) Having a R.H. RP/4 rake or a R.H. RP/5 rake or a R.H. RP/6 rake you can convert them into a L.H. RP/4 or L.H. RP/5 or L.H. RP/6 rake by replacing all wheel arms marked RIGHT with those marked LEFT.
- 2) Having a R.H. RP/4 rake you can convert it into a RP/8 V-rake by attaching a L.H. RP/4 rake and the relevant frame. To get one RP/10 V-rake from two RP/5 rake the procedure is still the same. To get one RP/12 V-rake from two RP/6 rake the procedure is still the same.
- 3) You could also use your V-rake as two single ones, L.H. or R.H. rake, according to your requirements.

SPECIFICATIONS

MODELS	RP/4	RP/5	RP/6	RP/8	RP/10	RP/12
Weight	180Kg/396lbs	200Kg/440lbs	250Kg/551lbs	460Kg/1013lbs	520Kg/1146lbs	620Kg/1366lb
Number of wheels	4	5	6	8	10	12
Number of tines on each wheel	40	40	40	40	40	40
Wheel diam.	1,4 m / 55"	1,4 m / 55"	1,4 m / 55"	1,4 m / 55"	1,4 m / 55"	1,4 m / 55"
Raking working width	2,6 m / 8' 6"	3,5 m / 11' 6"	4,1 m / 13' 6"	5,5 / 18' 1"	7,5 m / 24' 7"	8,7 m / 28' 6"
Turning and spreading working width	2,9 m / 9' 6"	3,9 m / 12' 10"	4,4 m / 14' 5"	6,1 / 20"	8,7 m / 28' 7"	10 m / 32' 10"
Transport width	2,2 m / 7' 3"	2,3 m 7' 6"	2,3 m / 7' 6"	3,6 m 11' 10"	4,7 m / 15' 5"	4,7 m / 15' 5"
Working speed	22 kmh/14mph	22 kmh/14mph	22 kmh/14mph	22 kmh/14mph	22 kmh/14mph	22 kmh/14mph
KW/HP required min.	22 Kw / 30 HP	22 Kw / 30 HP	22 Kw / 30 HP	30 Kw / 40 HP	30 Kw / 40 HP	30 Kw / 40 HP

RP/4-RP/5 AND RP/6 RAKE ASSEMBLY INSTRUCTIONS

To save room in the container we supply the rakes partly knocked down. Here below please find assembly instructions. For part numbers please refer to the enclosed parts breakdown.

ASSEMBLING

- a) Position the parking stand (15) in its housing and lock it with the pin (13). Next, lay the primary structure (supplied assembled) on the ground with the swinging pipe (31) upwards (pict. 1).

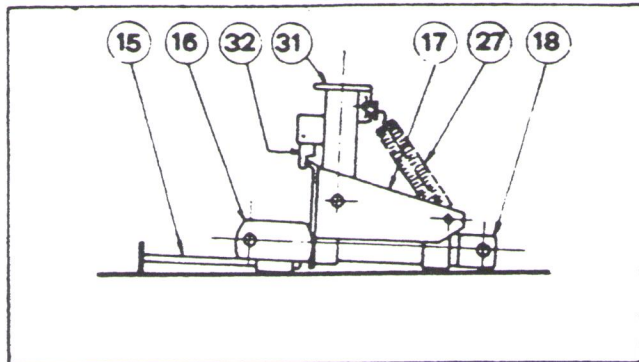

Pict. 1

- b) Slide the main pipe (37) into the swinging pipe (31) and retain with the supplied lever (33) and pin (36), so that it is on axle with the three point hitch (pict. 2).

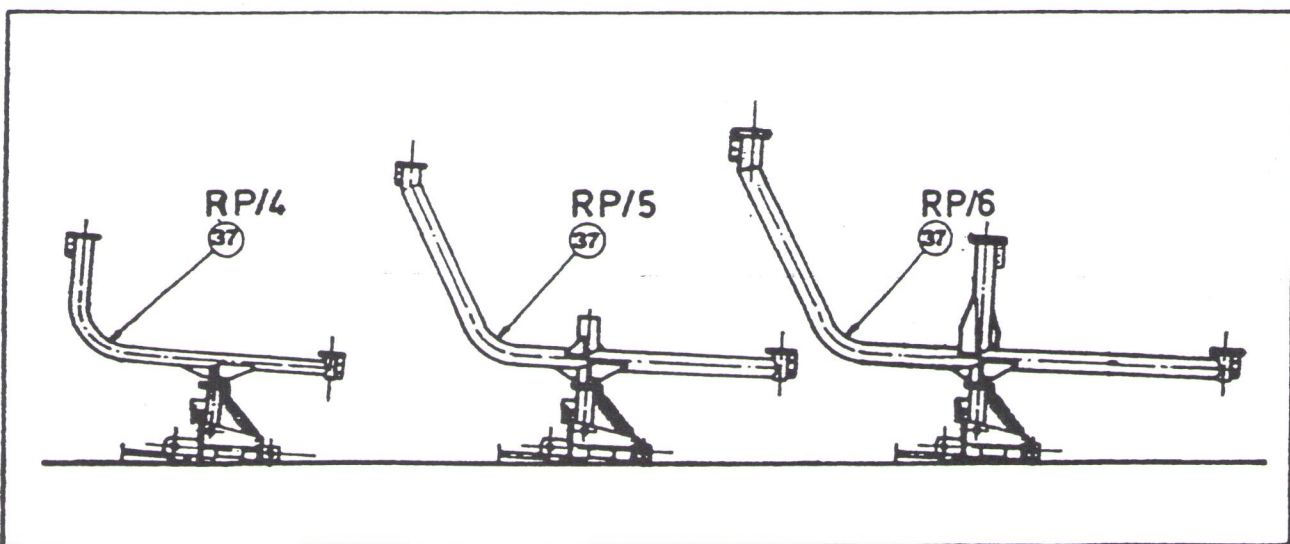

Pict. 2

- c) Attach the wheel arms (38) and lock them to the main pipe (37) with pins (36), so that they are on axis with the main pipe (37). For the RP/5 rake, attach also the central arm (55) to the main pipe (37) and retain with bolts (53-54-30) (pict.3).

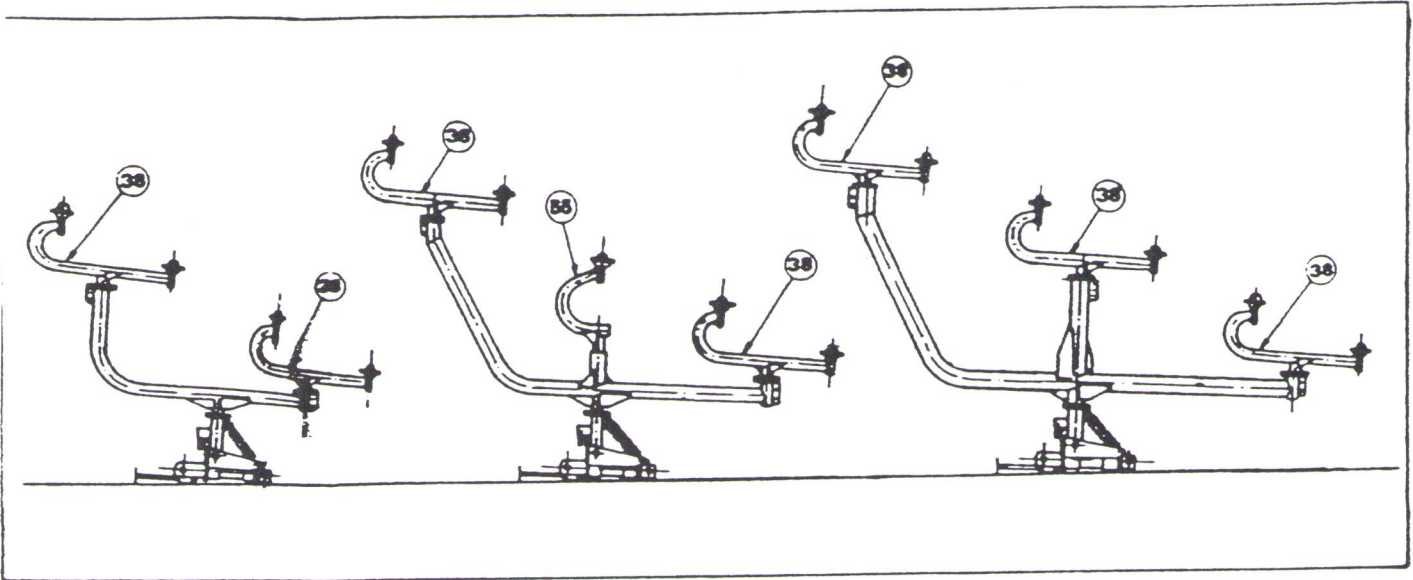

Pict. 3

- d) Attach the two central wheels (RP/4) or the three central wheels (RP/5) or the four central wheels (RP/6) to the supplied arm flanges (38-55) and bolt them with the supplied bolts (pict.4). when bolting the wheels (x) check that the tine clamps (48) are turned toward the hub.

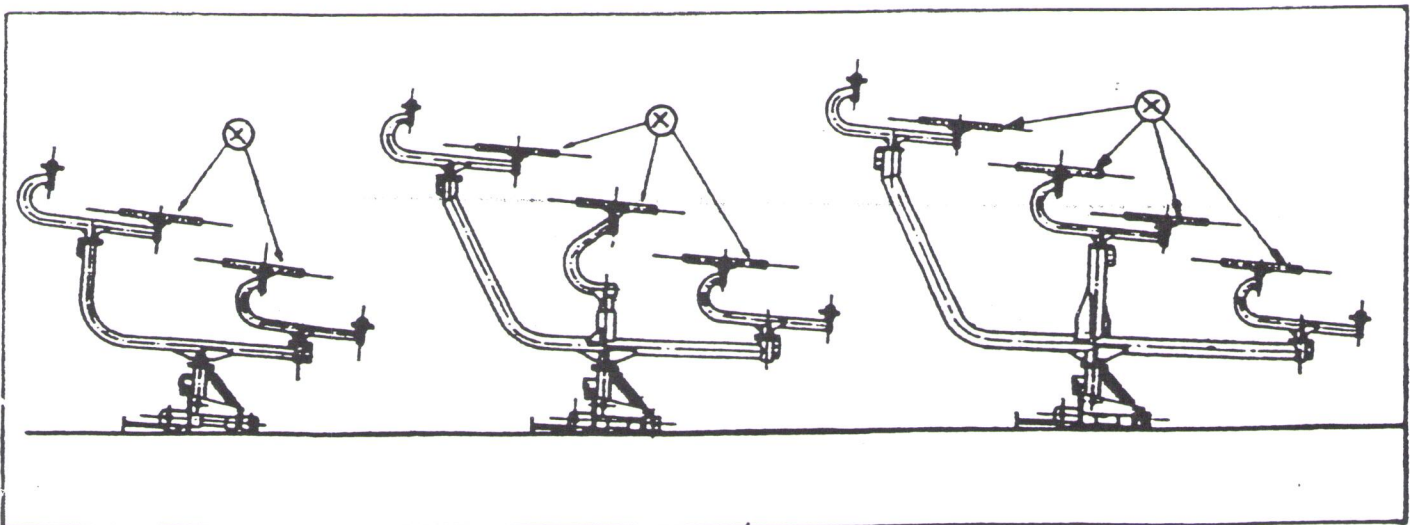

Pict. 4

- c) Lift the wheels (x) from the ground until they are in the working position (pict. 5).

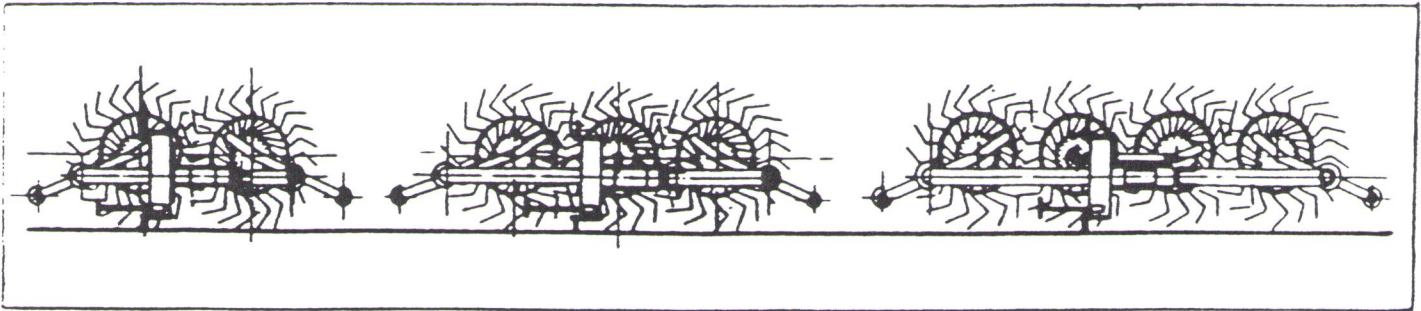

Pict. 5

- f) Unlock the primary structure with the supplied lever (33) and pin (36), turn it by 90 degrees and lock it again with the same pin. Now the rake is properly positioned on the ground and you only have to attach the remaining wheels as explained above.
The rake is now fully assembled and ready to be mounted to the tractor (pict. 6)

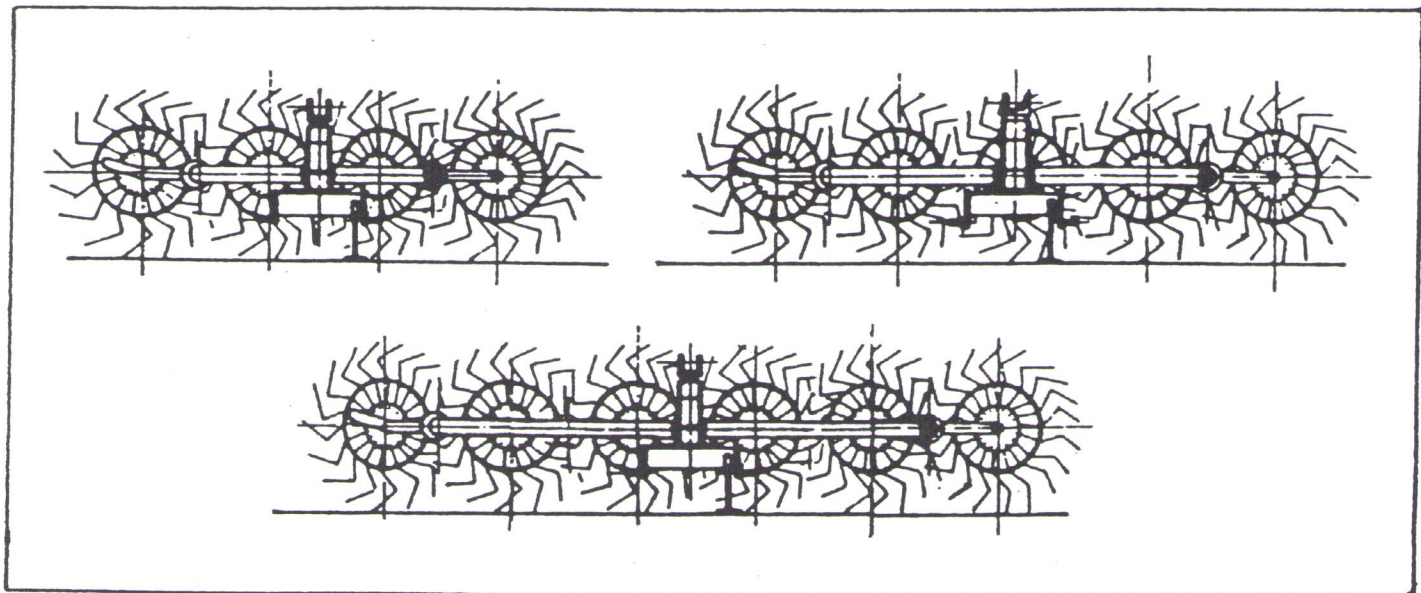

Pict. 6

IMPORTANT

Above are the instructions for the R.H. rake assembly. Please refer to the above instructions also for the L.H. rake assembly. Most parts are interchangeable for both rakes, only the specific parts are marked RIGHT or LEFT.

MOUNTING OF RP/4 AND RP/5 RAKE TO TRACTOR

When the rake is ready to be mounted to the tractor (pict. 6) attach the lifting arms to the pins on both sides of the primary structure (16).

Next, attach the three point arm to the cap (18) of the primary structure with the pin. Now lift the rake to its highest setting and for transport lock with the pin (32) for no rake floating (pict. 7).

Retain the part (17) to the crossbar (16) with the pin (19) into hole 1 (pict. 15) of the above said crossbar. Now turn the main pipe (37) and bring the rake to the vertical position for transport (pict. 8).

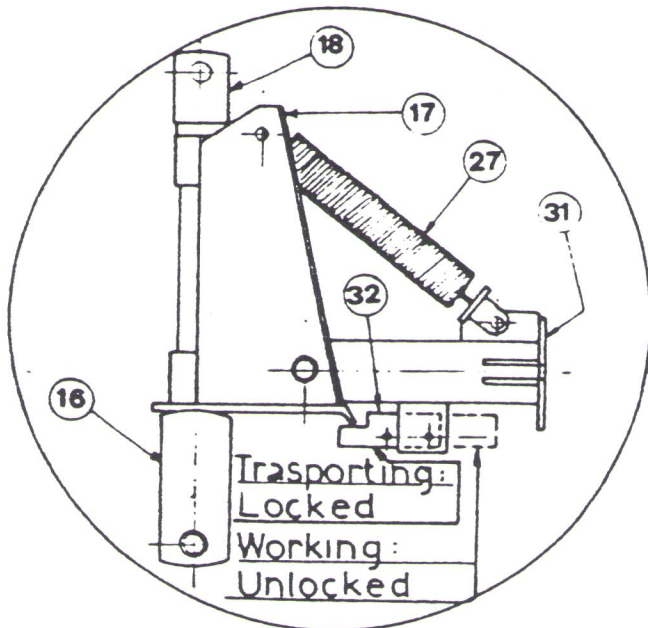

Pict. 7

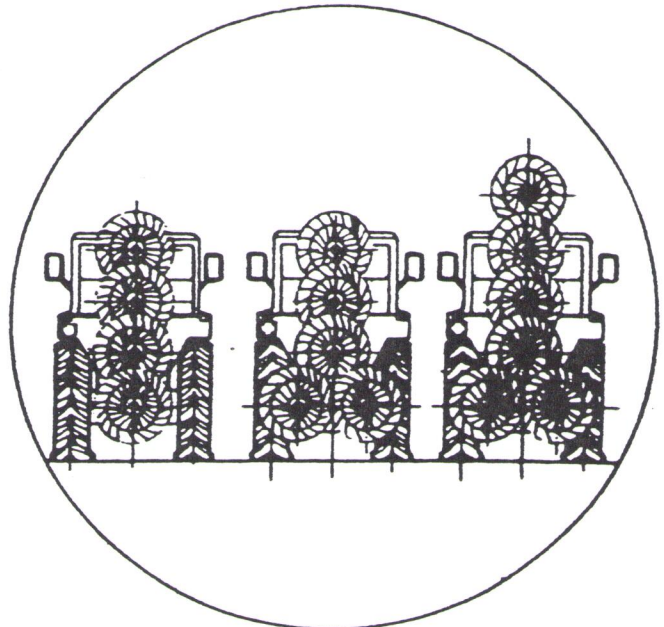

(Pict. 8)

VERY IMPORTANT

Never operate the rake with the pin (32) in the locked position. The locked position is for transport only (pict. 7).

RP/8-RP/10 AND RP/12 V-RAKE ASSEMBLY INSTRUCTIONS

RP/8 and RP/10 and RP/12 V-rakes are made as follows:

- no 1 main frame (1) complete of hitches (4-12)
- no 1 R.H. RP/4 or RP/5 or RP/6 rake, duly assembled as above.
- no 1 L.H. RP/4 or RP/5 or RP/6 rake, duly assembled as above.

IMPORTANT

On the R.H. and L.H. RP/4 and RP/5 and RP/6 rakes only the wheel arms and the wheels are specific, all other parts are interchangeable for both rakes. The specific parts are marked RIGHT (for the R.H. rake) and LEFT (for the L.H. rake).

ASSEMBLING

Attach the hitches (4-12) and relevant counterplates (5) to both ends of the main frame (1) - in the position show in picture 9 - with bolts (6-7-8)

Attach hitches (4-12) to the opposite side of the tractor's hitches welded on the frame (1) (pict. 10).

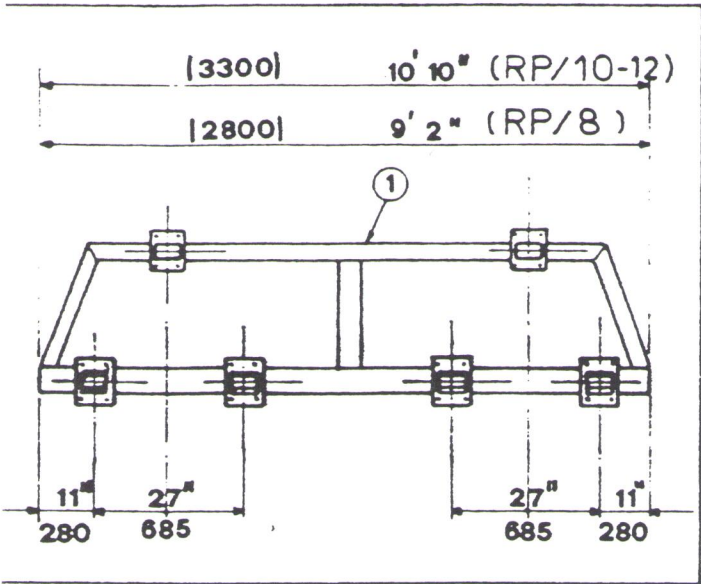

(Pict. 9)

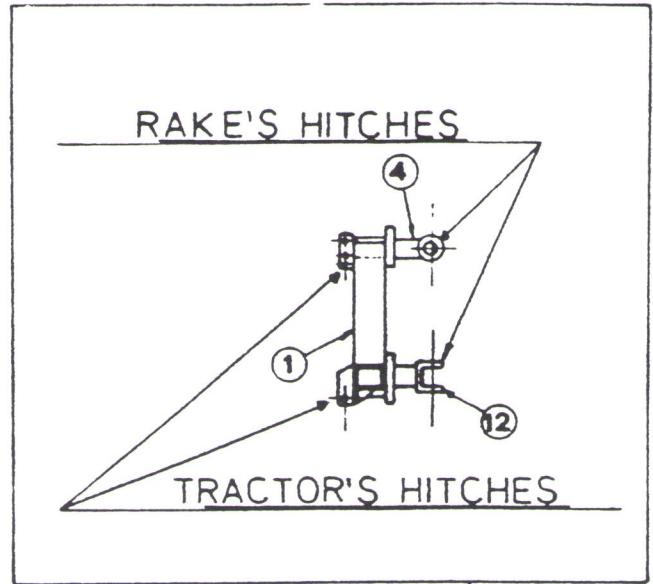

(Pict. 10)

Next, manually (pict. 11) or with a crane (pict. 12) lift the main frame (1) and bolt it to the tractor's lifting arms.

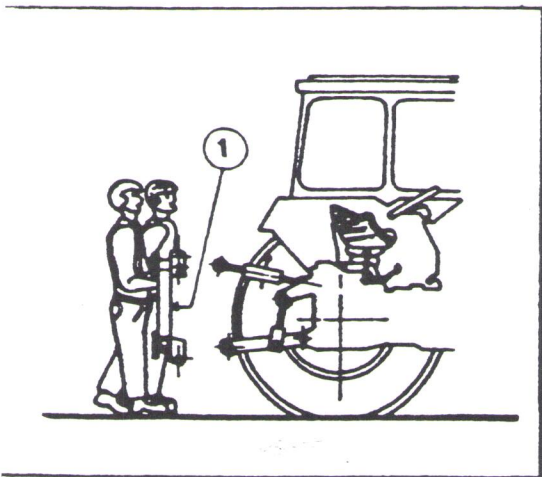

(Pict. 11)

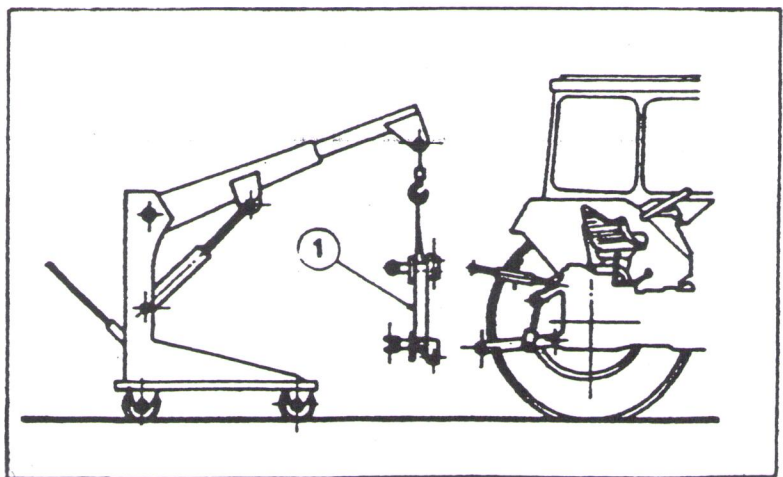

(Pict. 12)

ATTACHING THE RAKES TO THE FRAME

Attach hitches (12) of frame (1) to the lateral pins welded on the primary structure (16) of rake with the pins (11) and the split pins (10). Attach the upper hitch (4) to the cap (18) with the pin (9) and the split pin (10).

IMPORTANT

For the V-rake transport please refer to the RP/4 and RP/5 and RP/6 rake transport. Pictures 13 and 14 below show the transport position of RP/8 and RP/10 and RP/12 V-rakes.

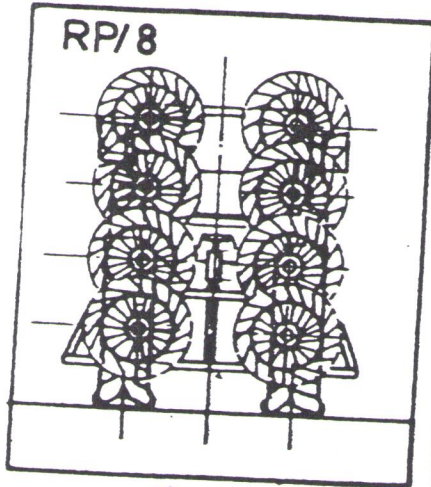

13

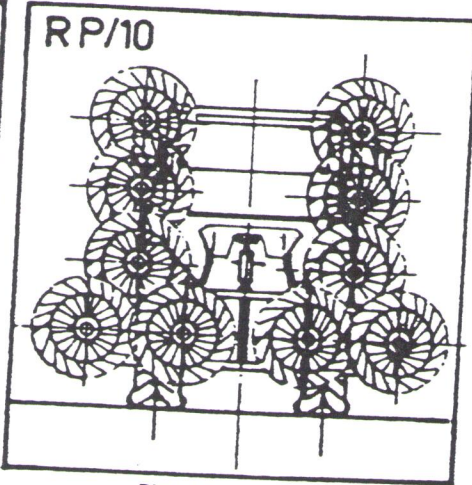

Pict. 13

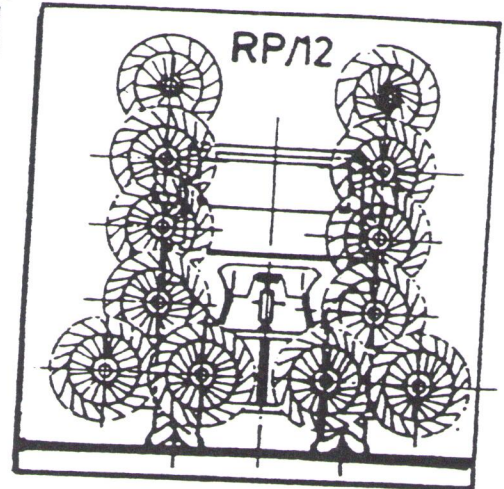

Pict. 14

ON THE FIELD

Before operating the rake and after you have reached the field, unlock pin (32) (pict. 7 and relevant notes). This will enable the rake to float independent of the main frame.

Next, adjust the rake working angle by positioning the pin (19) into the holes 2 to 7 (pict. 15). Hole 1 is for transport only.

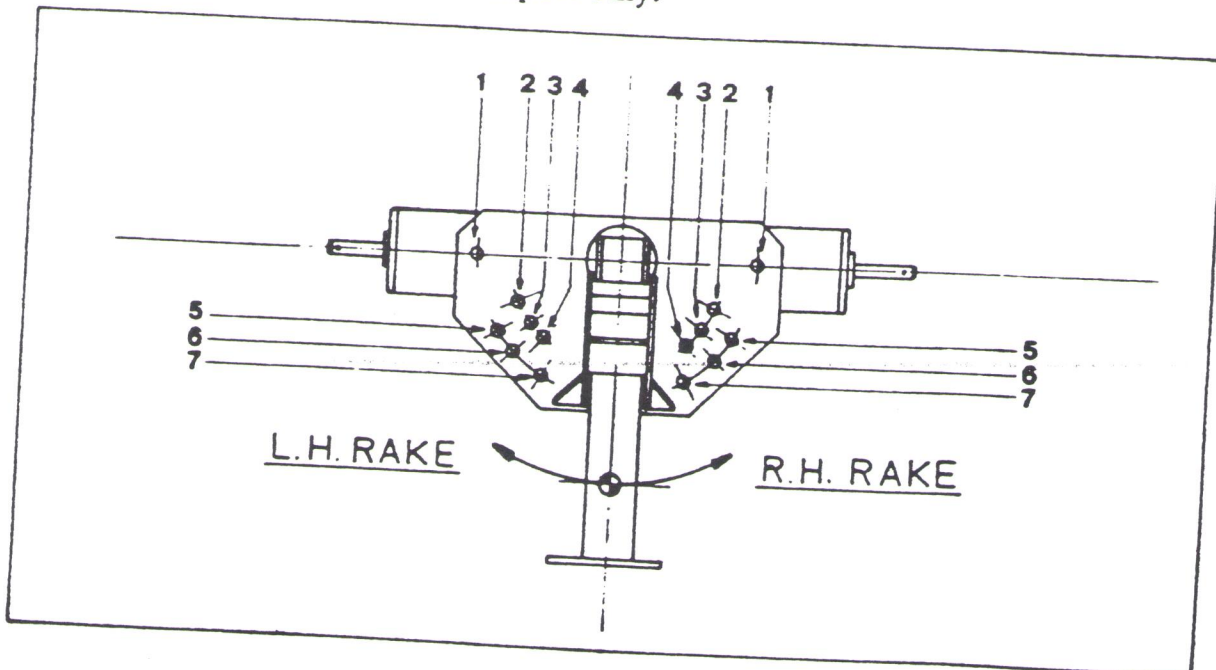

Pict. 15

ASSEMBLING

Attach the hitches (4-12) and relevant counterplates (5) to both ends of the main frame (1) - in the position show in picture 9 - with bolts (6-7-8)

Attach hitches (4-12) to the opposite side of the tractor's hitches welded on the frame (1) (pict. 10).

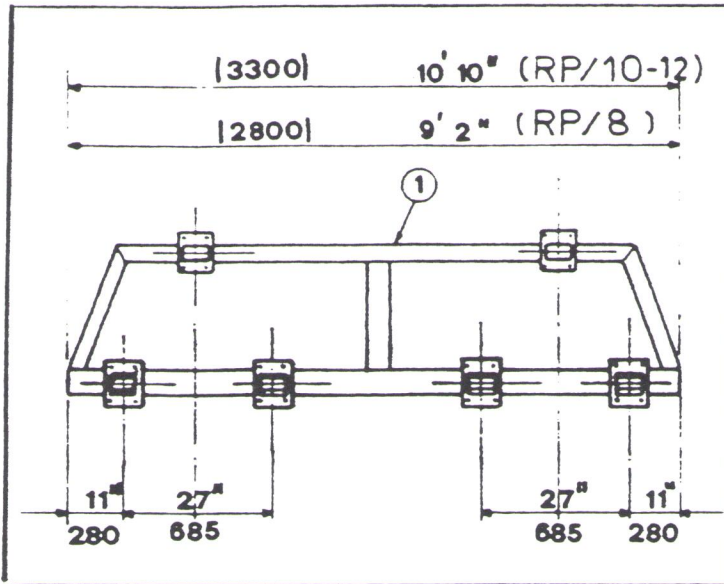

(Pict. 9)

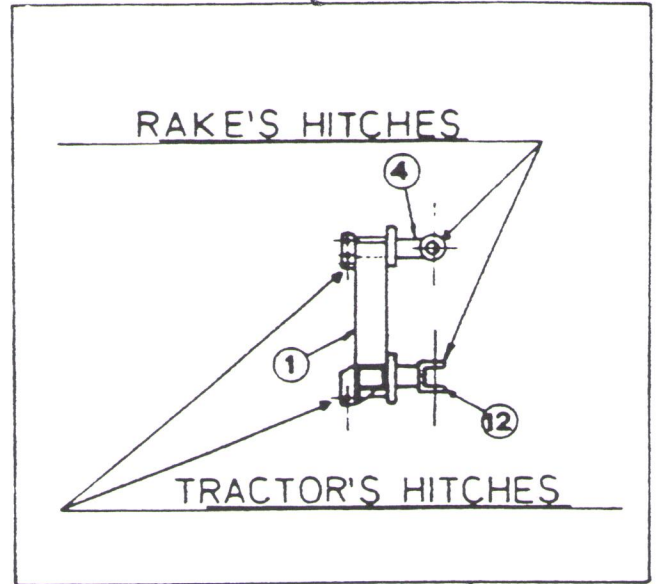

(Pict. 10)

Next, manually (pict. 11) or with a crane (pict. 12) lift the main frame (1) and bolt it to the tractor's lifting arms.

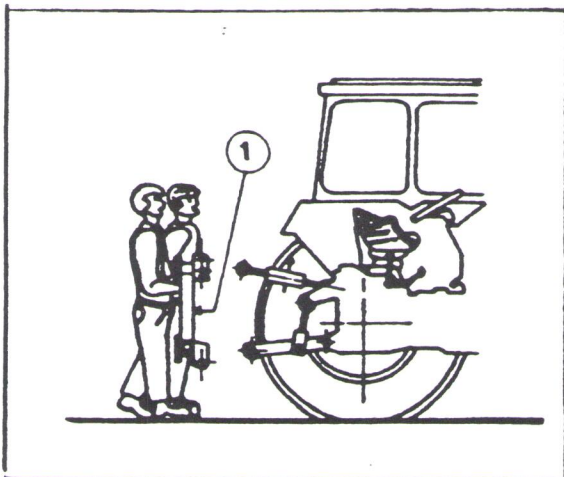

(Pict. 11)

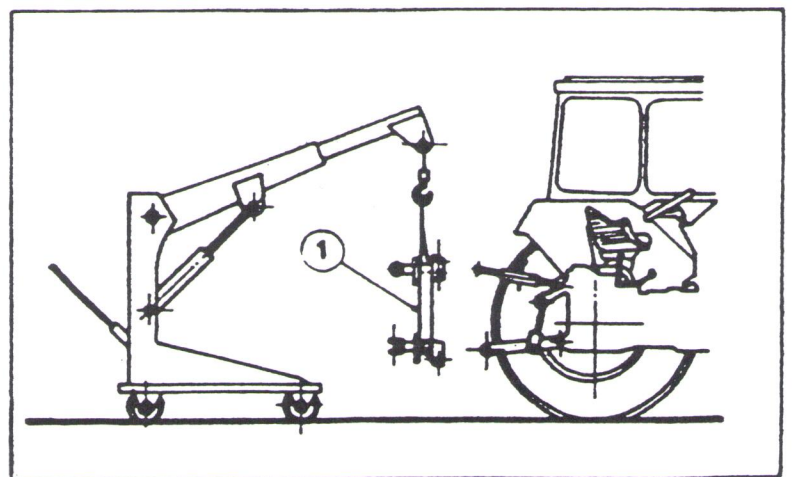

(Pict. 12)

The rake is suitable for:

1) RAKING (pict. 16)

Turn the main pipe (37) with the bend to the left.

Turn the wheel arms (38) (on RP/5 rake turn the wheel arm 55 as well) with the bend to the left.

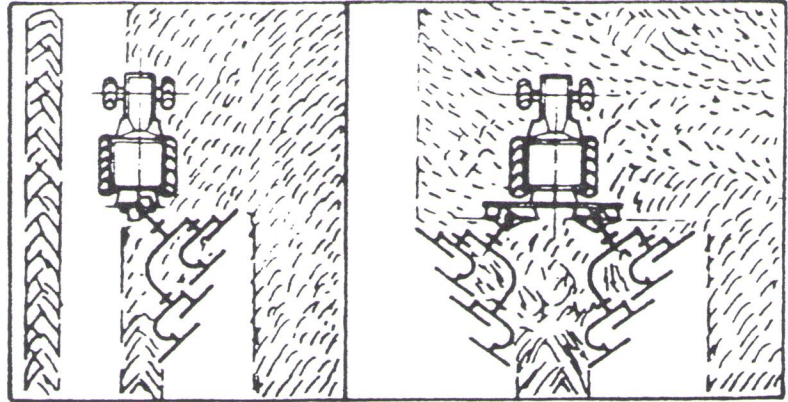

Pict. 16

2) SPREADING (pict. 17)

Turn the main pipe (37) with the bend to the left.

Turn the wheel arms (38) (on the RP/5 rake turn the wheel arm 55 as well) with the bend to the right.

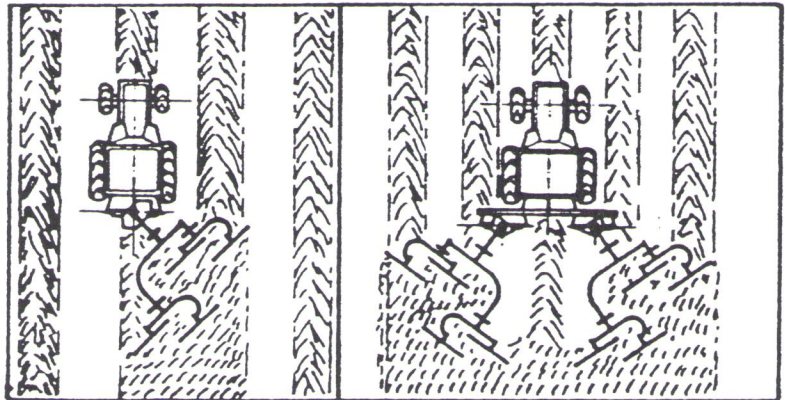

Pict. 17

3) TURNING (pict. 18)

Turn the main pipe (37) with the bend to the right.

Turn the wheel arms (38) (on RP/5 rake turn the wheel arm 55 as well) with the bend to the left.

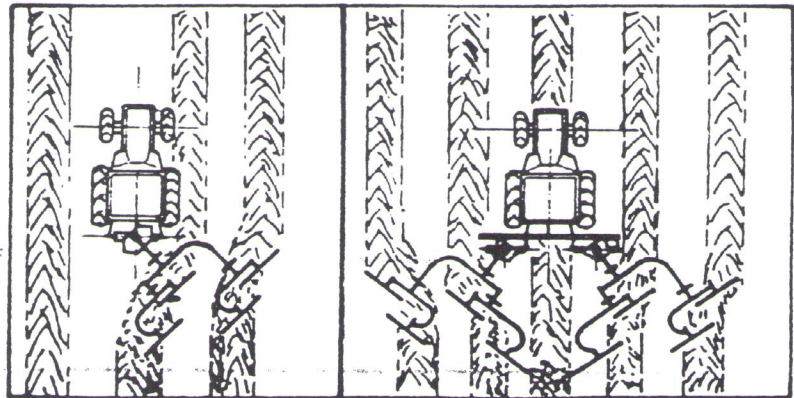

Pict. 18

IMPORTANT

Above we have described how to set a R.H. rake for the different operations. If you need to set a L.H. rake for the above operations, please refer to pictures 16-17 and 18 of V-rakes.

ON THE FIELD WITH RP/8-RP/10 AND RP/12 V-RAKES

RP/8 and RP/10 and RP/12 V-rakes are properly designed for windrowing, as ideal implement to complement the big balers. Slide the RP/4 or RP/5 or RP/6 rakes on the frame (1) to get different working widths.

Below (pict. 19-20) the ideal positioning of the rake for a swath suitable for a 5' pick-up baler.

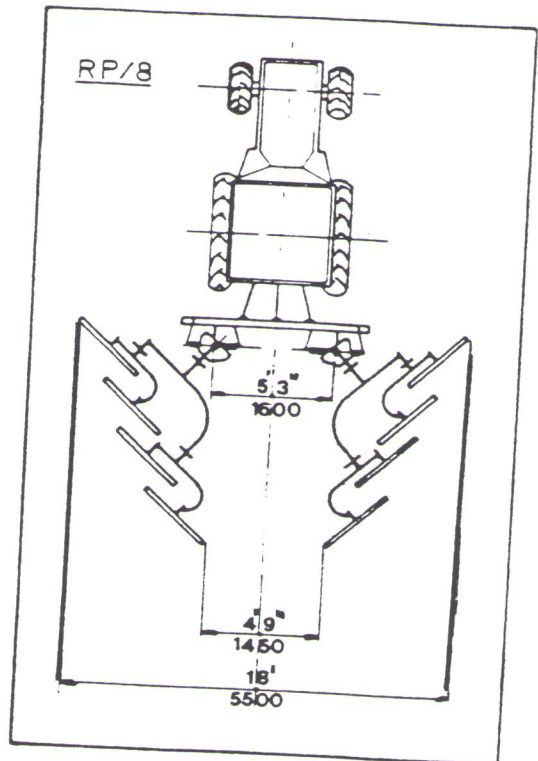

19

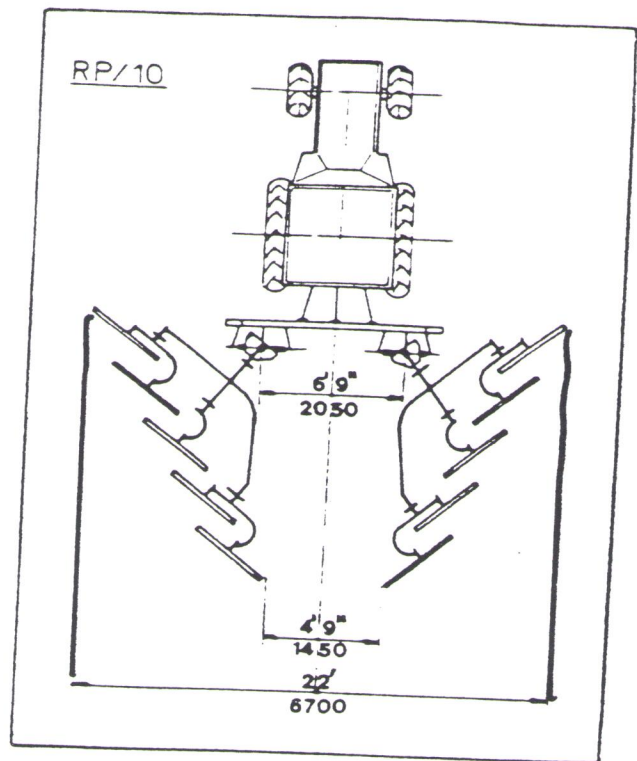

20

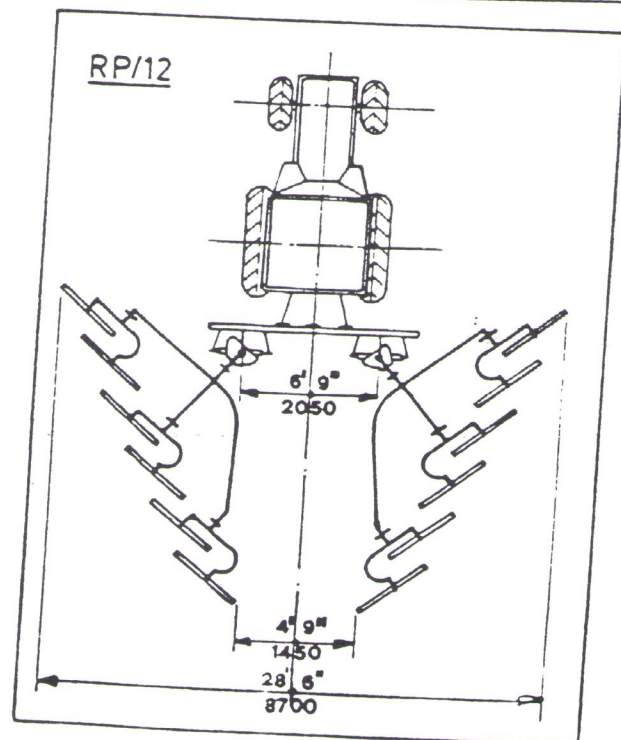

FEATURES

hayrakes are basically made of a primary structure of bent steel pipes, which make the implement particularly sturdy and flexible. Tines are also very flexible, many are the possible adjustments of the rake, and the implement can work fast and successfully even on slopes or on stony and rough soils.

The wheel hubs are made of pressed steel and are equipped with taper roller bearings, protected with a dust cover, so that the wheels can properly turn.

MAINTENANCE

On rakes no maintenance is required. As a matter of fact no maintenance is required for all gearings, wheel hubs (equipped with 1st quality taper roller bearings and protected with a dust cover) and all setting operations.

No special tools are therefore required for servicing.

However, when the season is over, we recommend to clean the implement, to protect it from rust by oiling and store it until next season.

IMPORTANT

Every rake is provided with an identification label, as follows:

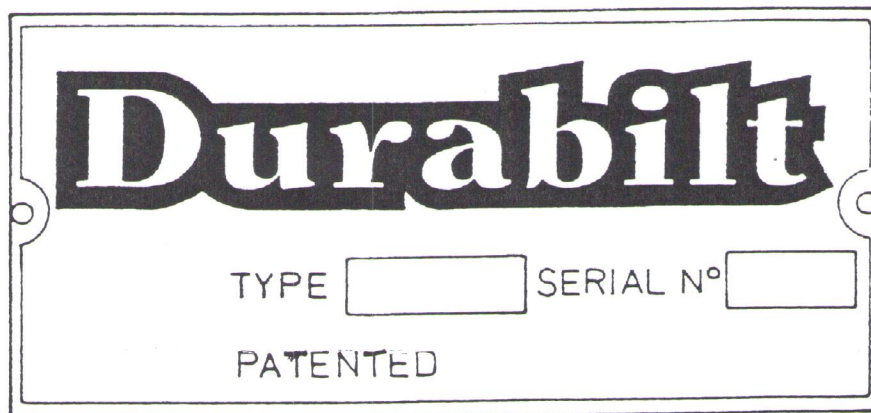

We recommend the use of original spare parts only, to get your implement working well for a long time. By ordering spare parts please always refer to the parts breakdown provided with this manual.

TROUBLES**CAUSES****REMEDIES**

1) Wheel does not unload hay	1) New tine, too much paint on it. 2) Mud on tine point due to moist soil.	1) Have the wheels be turning on gravelly soil until the tine is clean again. 2) The wheels are too close to the ground
2) Tine failure	1) Going backwards with wheels not lifted. 2) Too much pressure on the wheels. 3) Tine rusted.	1) Lift the wheels before going backwards. 2) Lightly lift the rake. 3) Protect it by oiling.
3) The rake does not collect the hay	1) The wheel is too much inclined to the ground. 2) Tine worn out.	1) By setting the 3rd point arm, bring the wheel vertical to the ground. 2) Replace it. We recommend to replace all tines for uniform height.
4) Too much floating of wheels.	1) Wheels too far from ground.	1) Lightly lower the rake.
5) Bent tine	1) Going backwards with the wheels not lifted. 2) Too much speed on rough soil. 3) Going across deep and narrow ditches or prominences. 4) Too much weight on the wheels.	1) Lift the wheels when going backwards 2) Reduce speed. 3) Reduce speed. 4) Lightly lift the rake.

Durabilt

Durabilt Industries, Inc. • P.O.Box 717 • Pocahontas, AR 72455 • (501) 892-4501 • FAX (501) 892-0729